



Power Electronic Converters; (Mis)Matching of Expectations

4-5-2011

Braham Ferreira

Power Electronics is Multidisciplinary

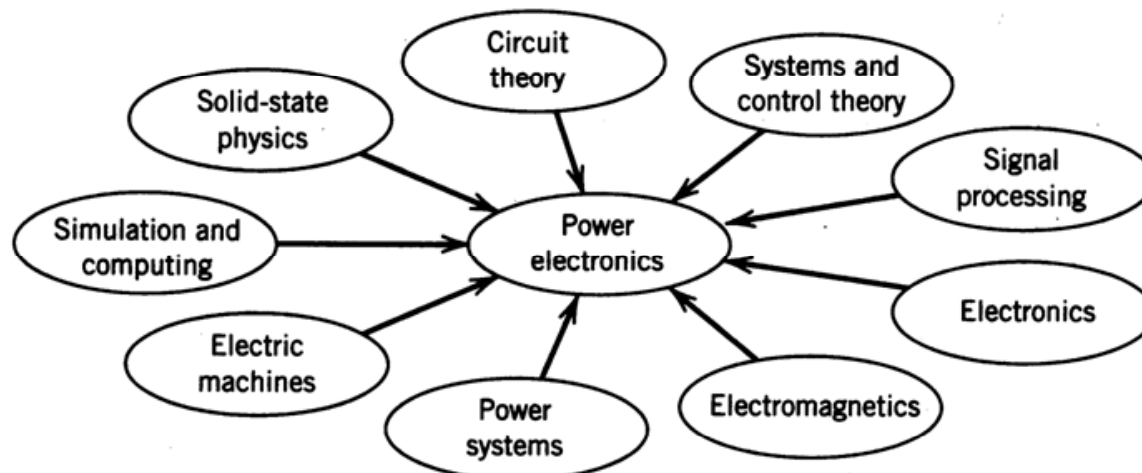

It is a well established engineering science that developed over a period of 50 years requiring many skills

..... and is constantly evolving.

Now the power electronics evolution is accelerating

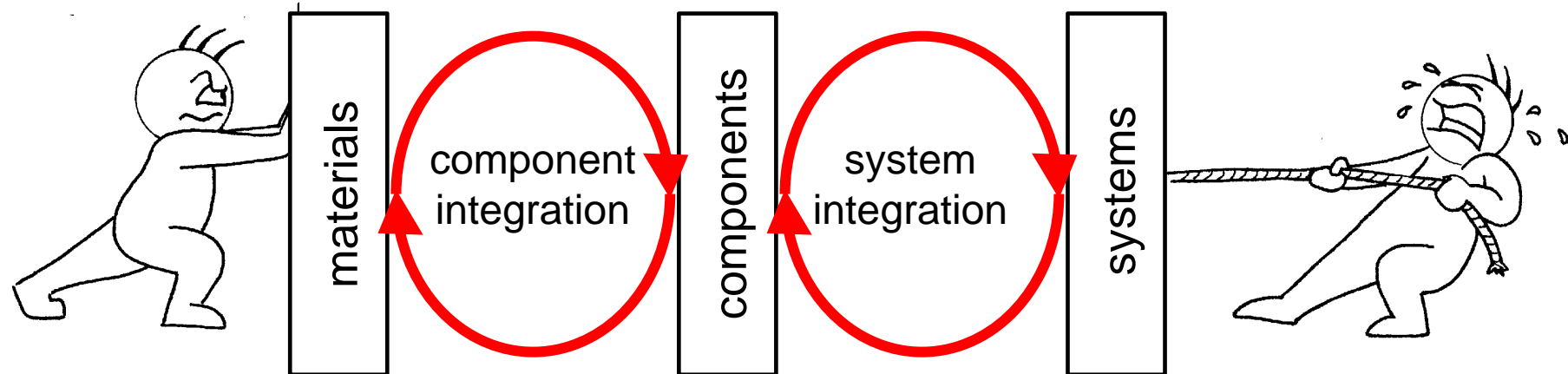

Technology Push

- Wide bandgap semiconductors
- ICT technologies
- Assembly & production technologies

Applications pull

- Smart Grids
- Energy savings
- e-Mobility
- LED lighting

.....



Outline

- Energy savings as technology driver at the user
- Power System versus Power Electronics viewpoints of the Smart Grid
- What does power electronics have to provide in future systems?

Energy Savings Potential of Power Electronics

Half of the EU SET target

- Predicted EU-25 electricity consumption in 2020: 4000TWh;
- SET plan: reduce total energy consumption by **20%** by 2020;
- Power electronics savings potential: **1150TWh** or **30%** of the predicted EU-25 electricity consumption;
- 40% of total energy consumption is electrical energy → power electronics can achieve **half of the SET target!**

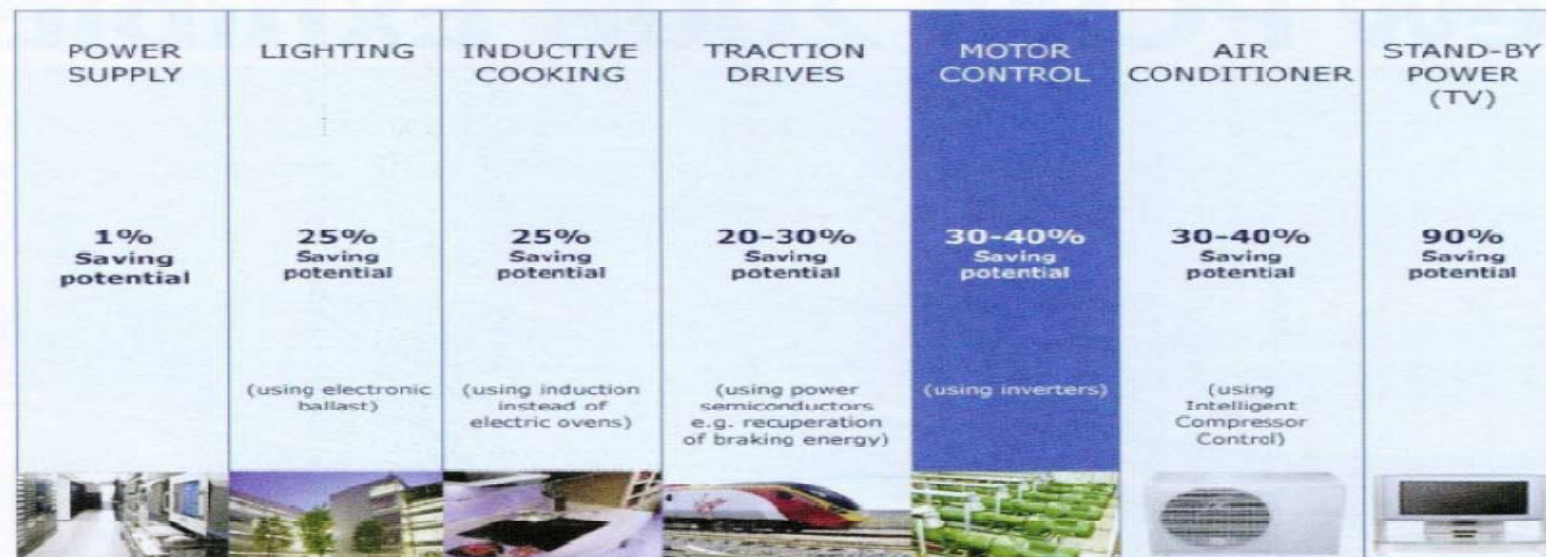

Power Electronic System efficiency has become a moving target

- EC regulations, Ecostar,
- Roadmaps by industry consortia: PSMA, EPSMA, ECPE.....
- For example:

Organization	Area	V/M	Key Specifications	Status
ENERGY STAR Enterprise server spec v1	US	V	Covers computer server, blade server, and chassis server having 1 – 4 processors. Min efficiency requirement – single output voltage: 81% minimum efficiency at 10%, 87% at 20%, 90% at 50% and 89% at 100% and 100% of rated output. Min efficiency requirement – multiple output voltage: 82% at 20%, 85% at 50% and 82% at 100% of rated output. Minimum Power Factor : 0.8 at 10%, 0.85 at 20%, 0.9 at 50% and 0.9 at 100% of rated output. DC powered servers, idle power, and power management are still under consideration.	Under development. Moving towards a Jan 1, 2009 effective date

PSMA Power Technology Roadmap 2011

Efficiency improvement is stimulating the production of wide bandgap power devices

The R_{on} vs. Blocking Capability Relations

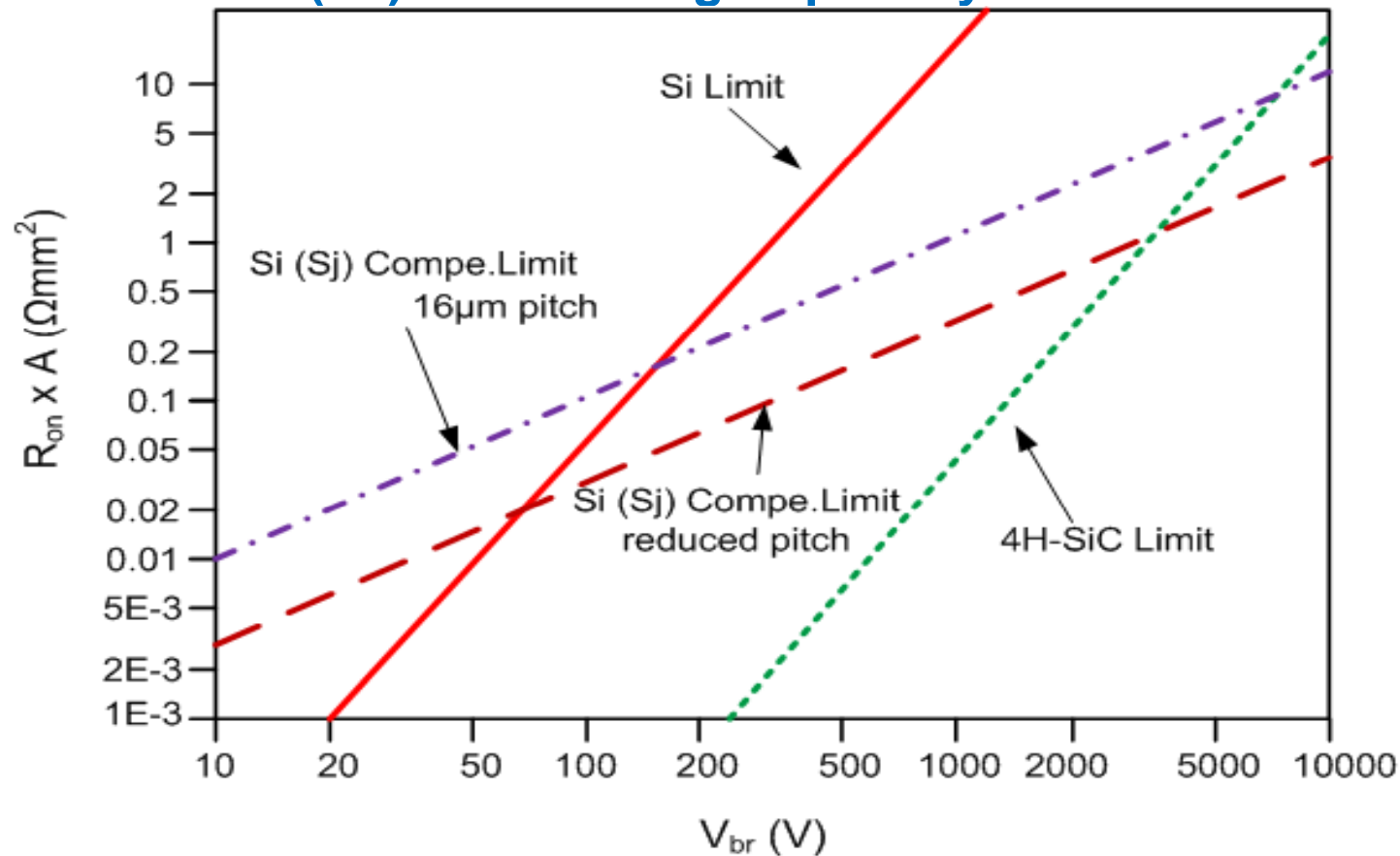

Example of efficiency improvement with SiC devices: ECPE industrial drive project

Si IGBT's and SiC freewheel diodes (2006)

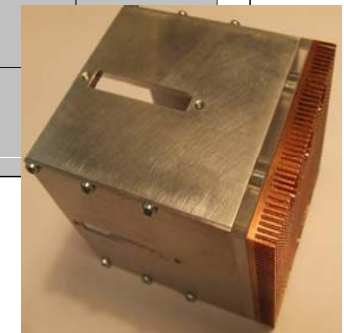
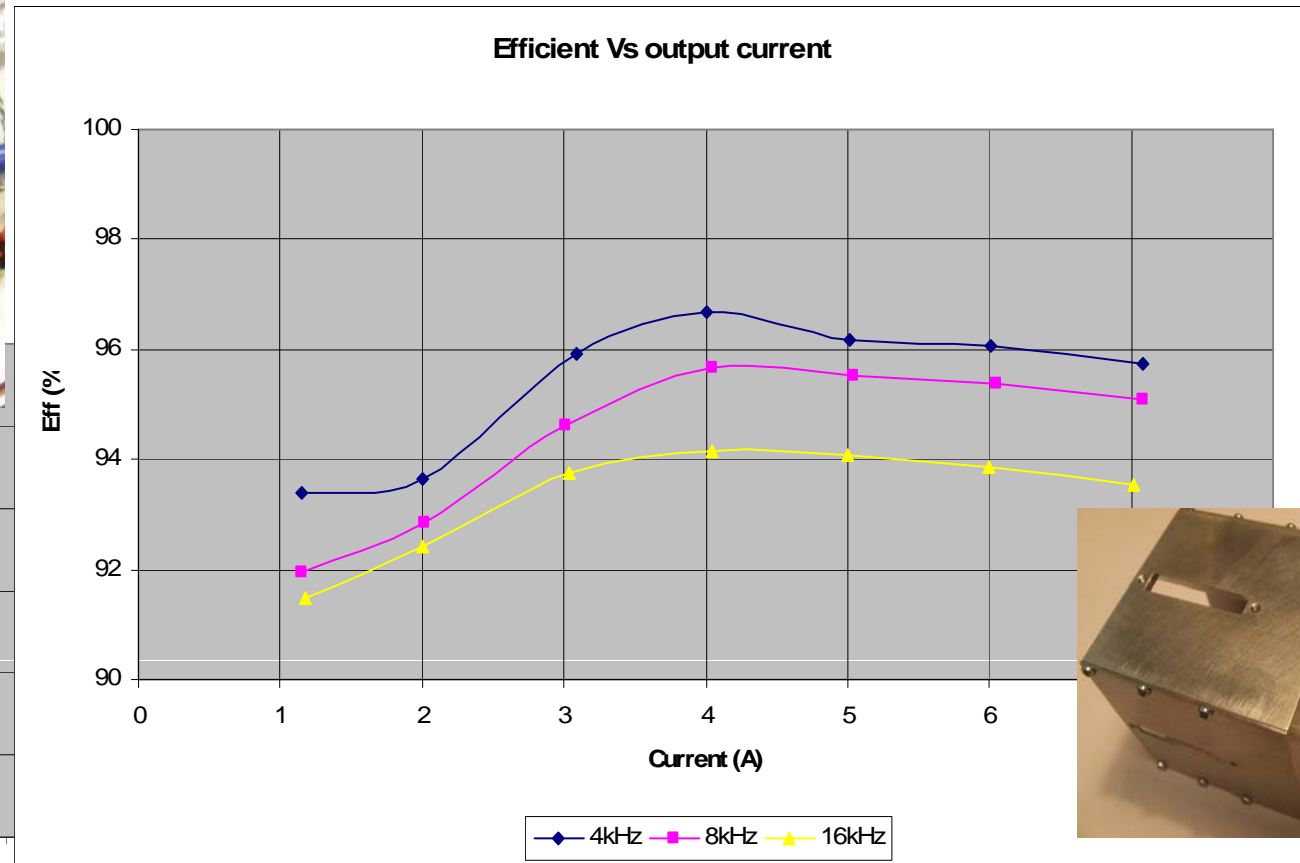
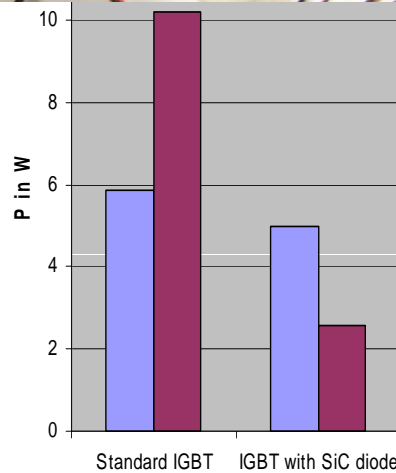
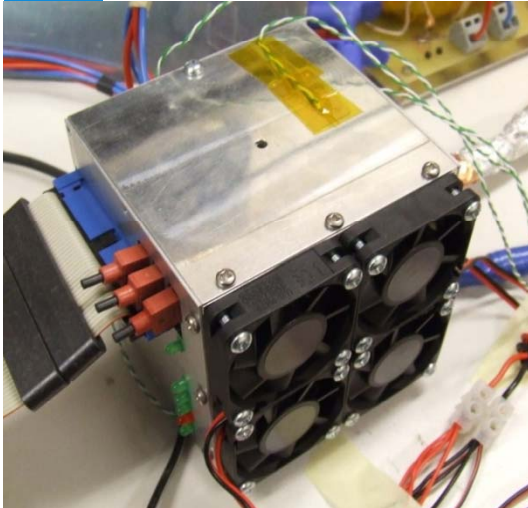

Example of efficiency improvement with SiC devices: ECPE industrial drive project

SiC JFET's and SiC freewheel diodes (2011)

SiC inverter efficiency vs. power at 40 °C

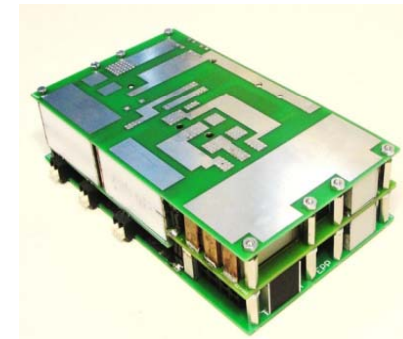
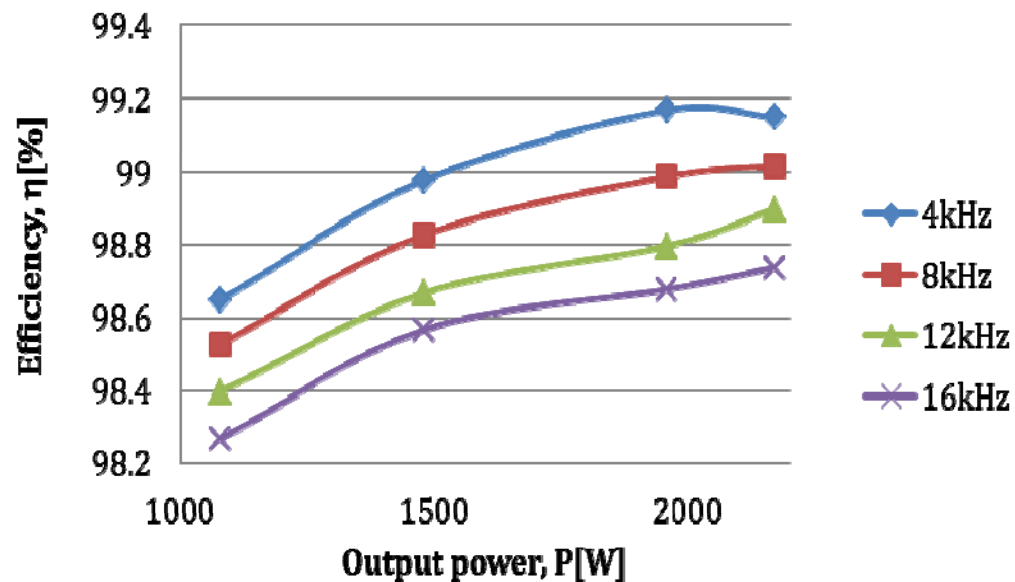

Outline

- Energy savings as technology driver at the user
- **Power System versus Power Electronics viewpoints of the Smart Grid**
- What does power electronics have to provide in future systems?

NIST Conceptual Model of the Smart Grid

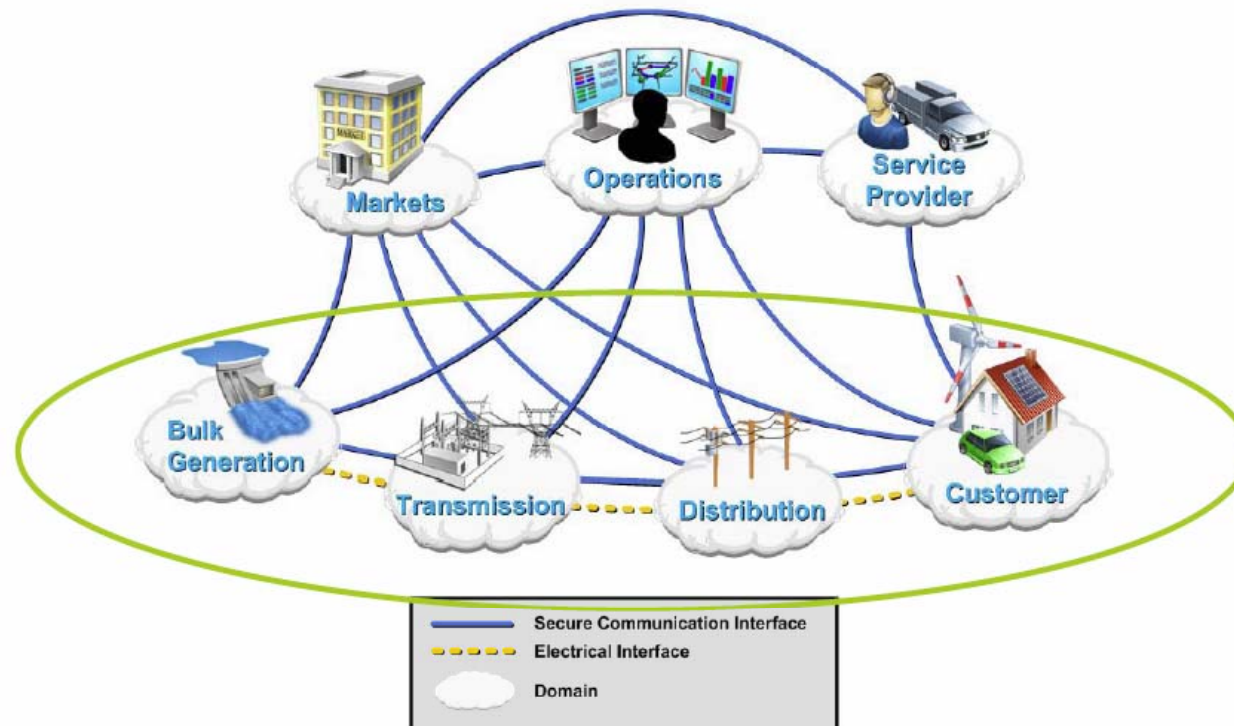

Electrical & communication interfaces

NIST = National Institute of Standards and Technology

Power Systems view Smart Grids: Merging of two infrastructures



Electrical (Smart) Infrastructure

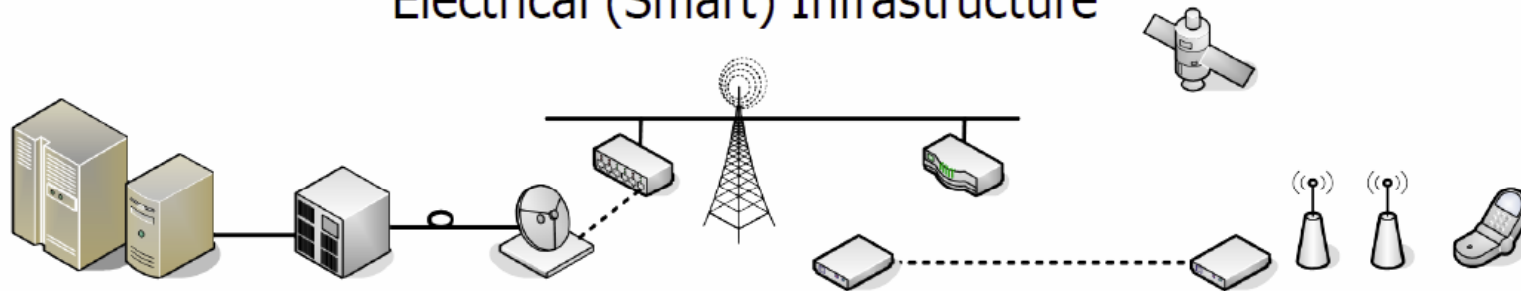

Controls and Communications (Smart) Infrastructure

Source: Prof. Riberio

Power Systems and ICT view of the role of Power Electronics in Smart Grids

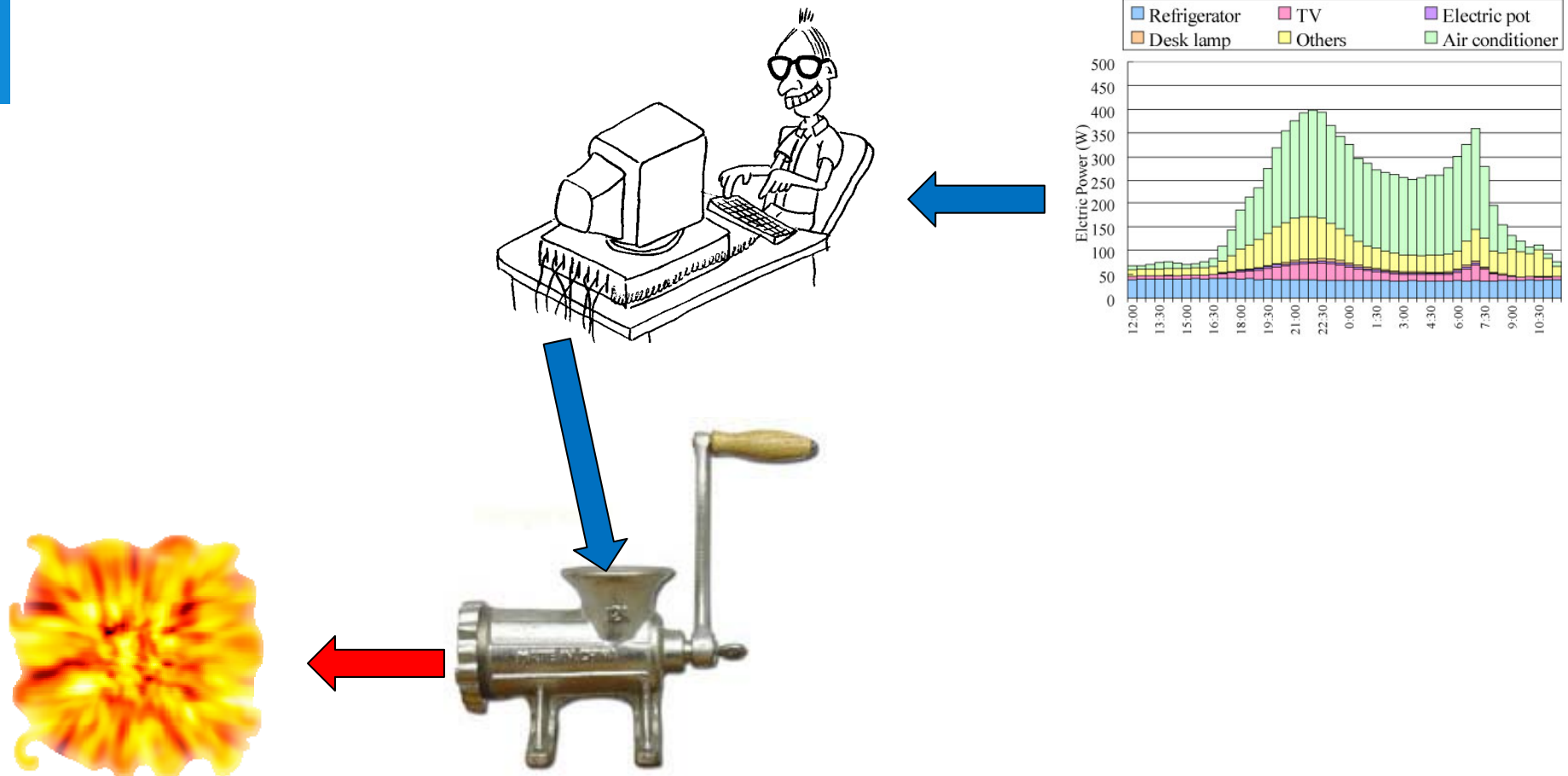

The Power Electronics Engineer's view

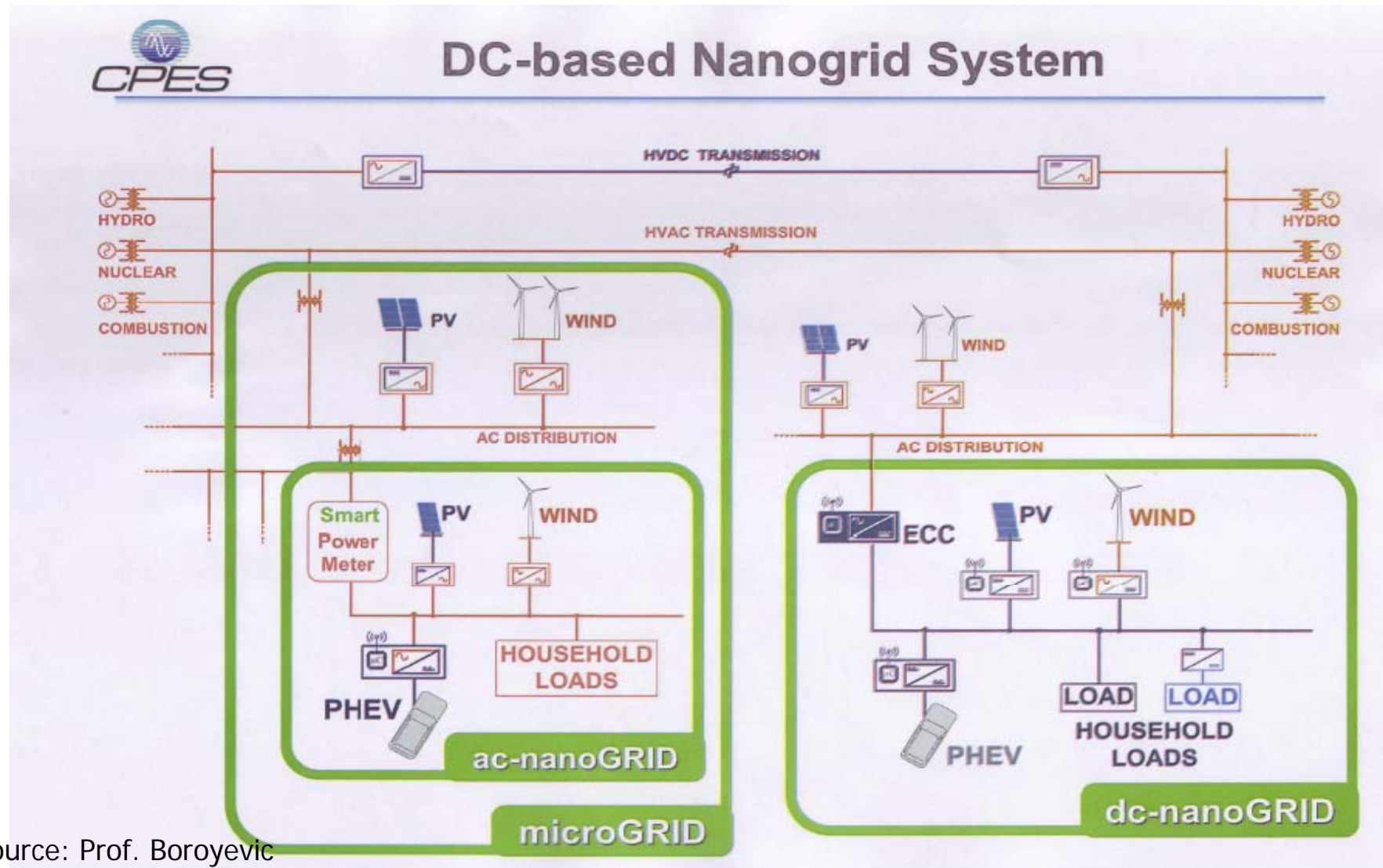

Source: Prof. Boroyevic

The Power Electronics Engineer's view

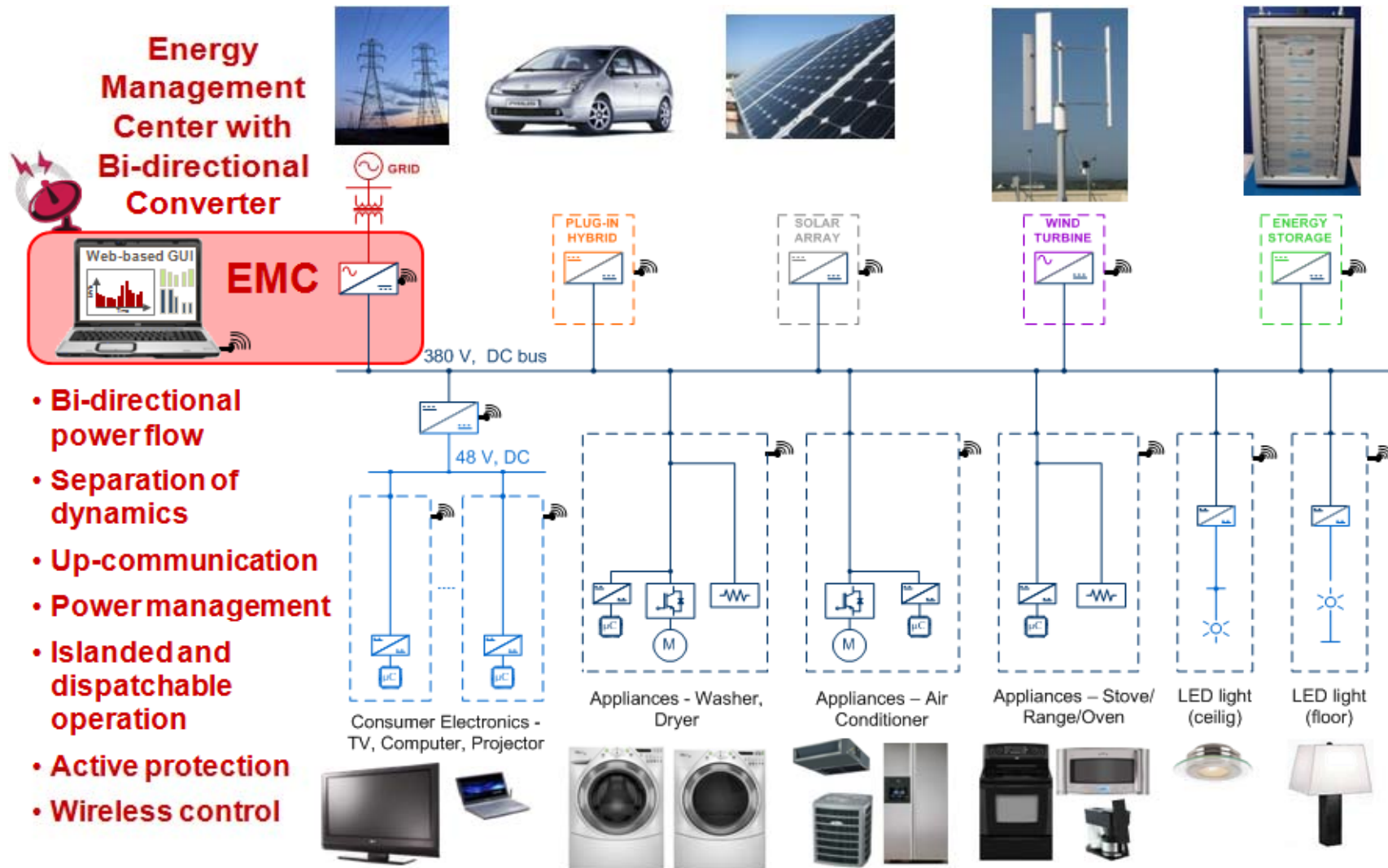

- Bi-directional power flow
- Separation of dynamics
- Up-communication
- Power management
- Islated and dispatchable operation
- Active protection
- Wireless control

Source: Prof. Boroyevic

Outline

- Energy savings as technology driver at the user
- Power System versus Power Electronics viewpoints of the Smart Grid
- **What does power electronics have to provide in future systems?**
 - **System compatible dynamics**
 - **Distributed power converters with distributed intelligence**
 - **Flexible personality for resilient power limiting grid operation**

Power System dynamics

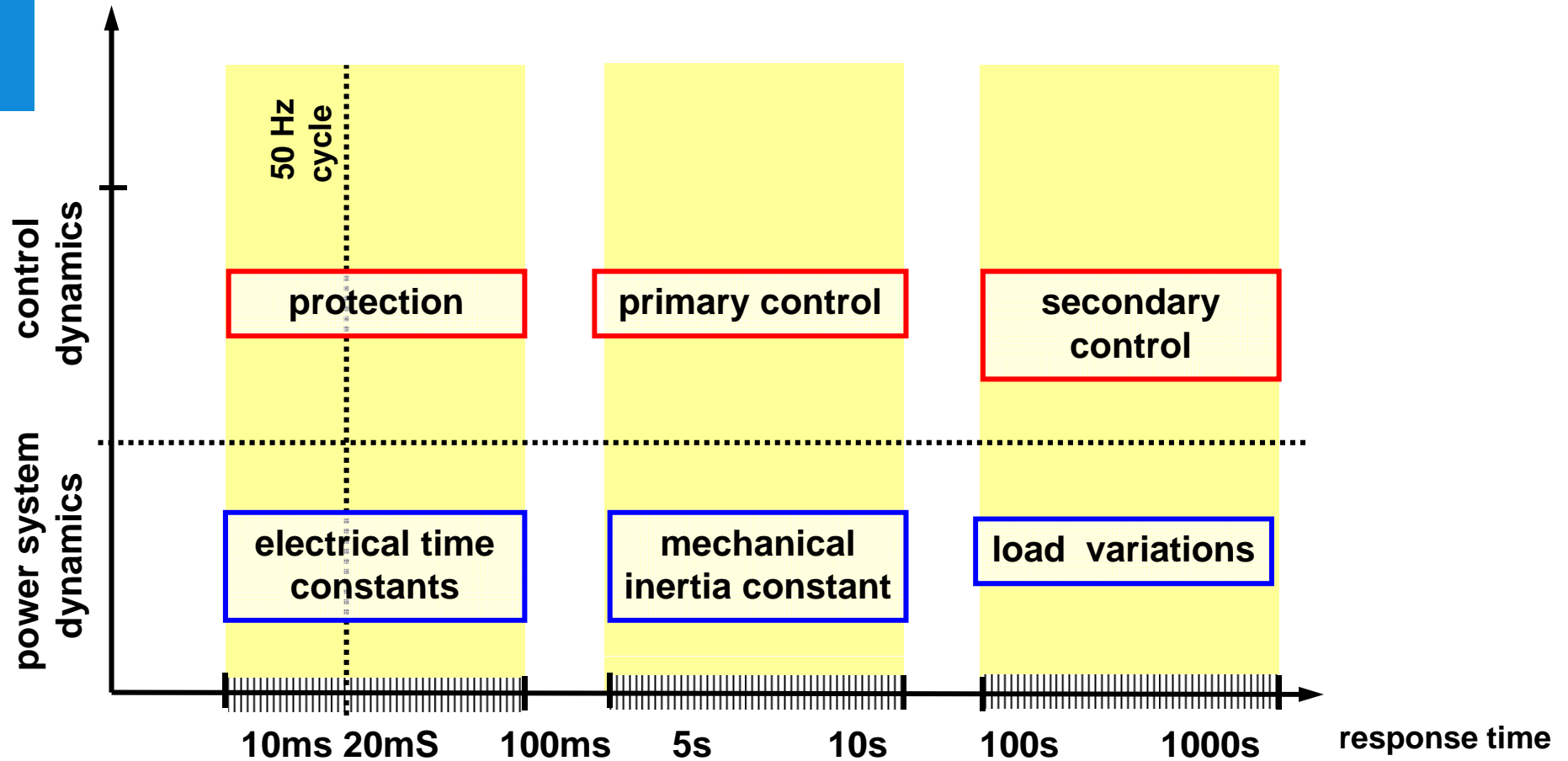

The inertial time constant is reduced by distributed generation.

- The power system has an inertial time constant of 5 – 10 s.
- PV generation has no rotational inertia.
- The inertial time constant scales with power.
- For example:

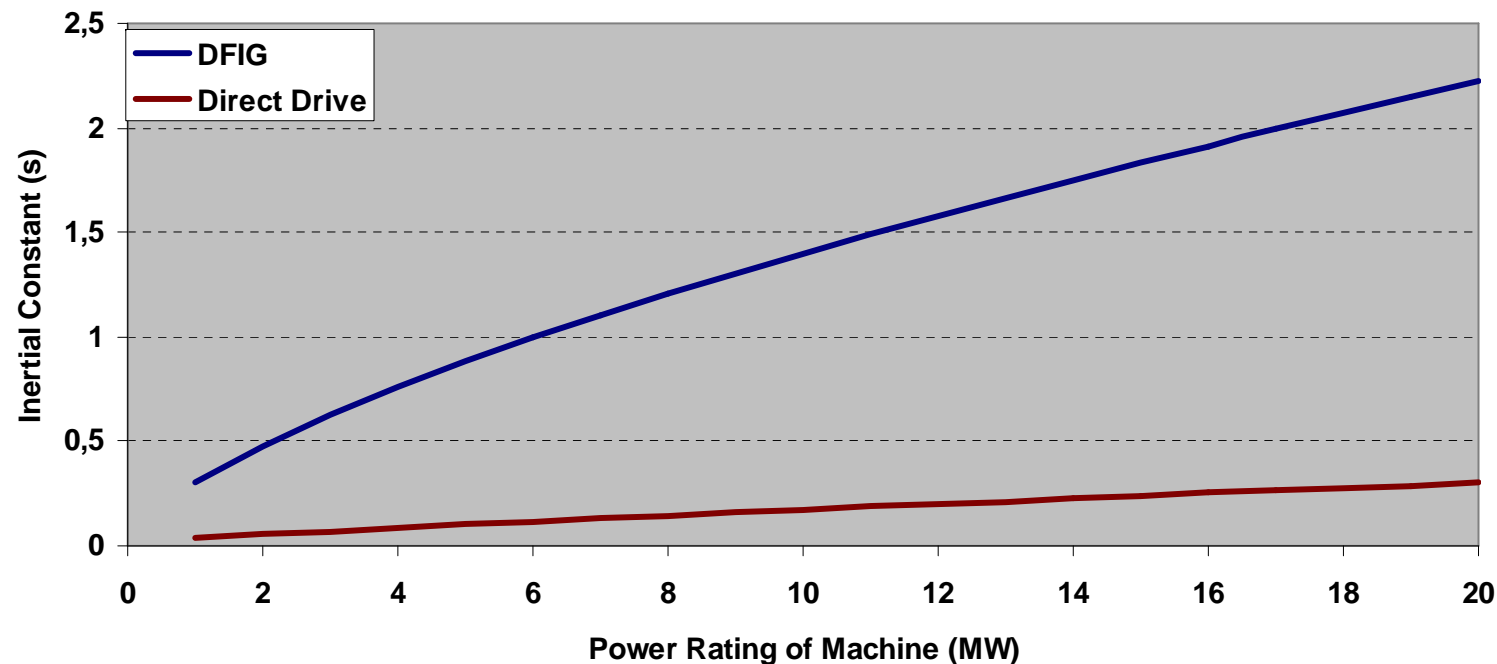

The mechanical inertial constant reduces as the central generation dwindles.

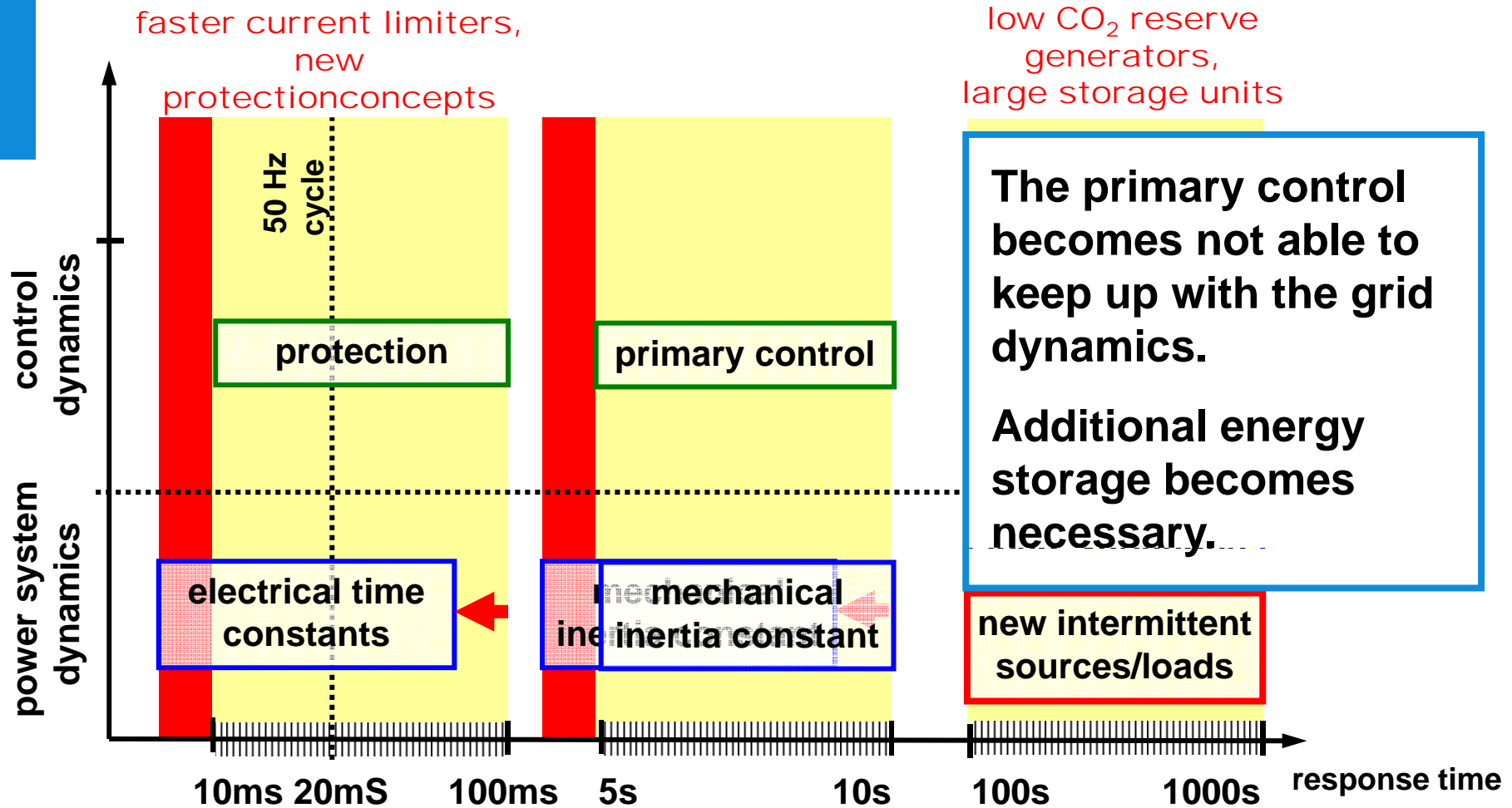

The Virtual Synchronous Generator introduces system compatible dynamics

- A virtual inertia can be attained for any distributed electricity generator by adding a short-term energy store.
- The principle of the Virtual Synchronous Generator can be applied either to every single distributed generator, or to groups of distributed generators.

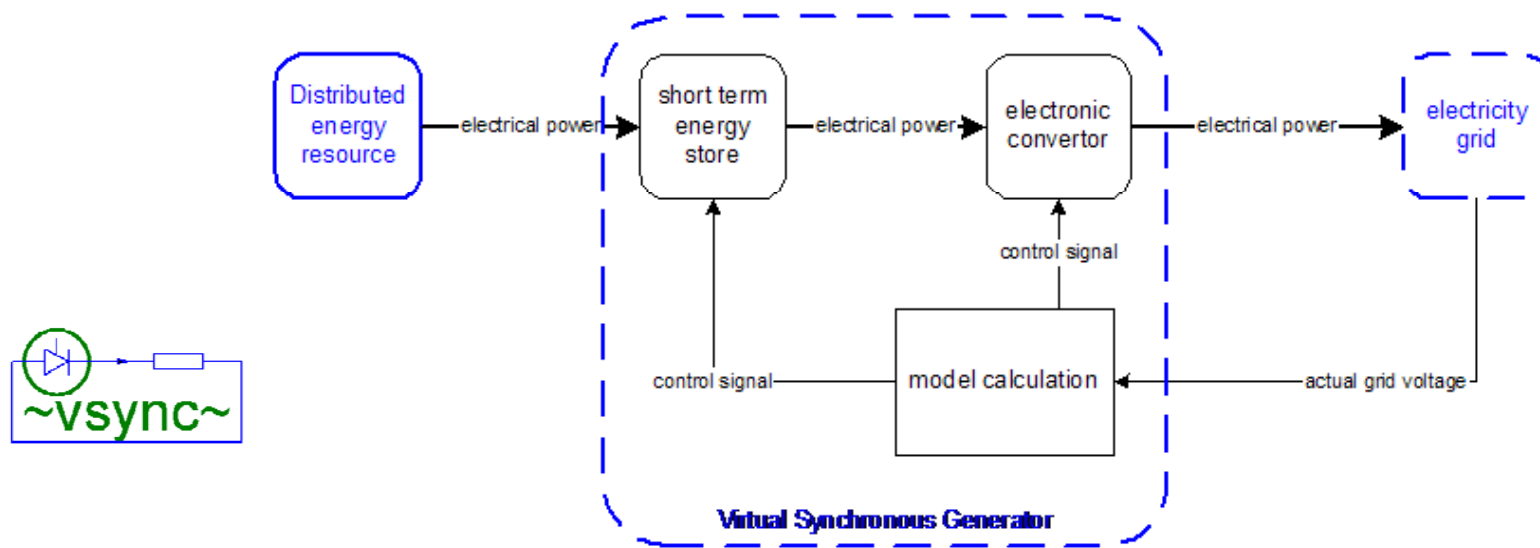

Distributed power converters with distributed intelligence

- Virtual solar power plant by distributed control

Petra Solar SunWave™ System



Smart Grid Management System

The Smart Grid Management System is composed of three main components: SunWave Energy Portal, SunWave NMS, and SunWave Kiosk. The SunWave Energy Portal displays a dashboard with various metrics and charts. The SunWave NMS displays a map of the system's location. The SunWave Kiosk displays a dashboard with various metrics and charts. A photograph of a SunWave AC Module is also included.

Distributed power converters with distributed intelligence

- Virtual power flow controller by distributed control

- Unity Power Flow Controller (UPFC) without common dc link:

- distributed, floating converter units
- Eliminate high voltage isolation

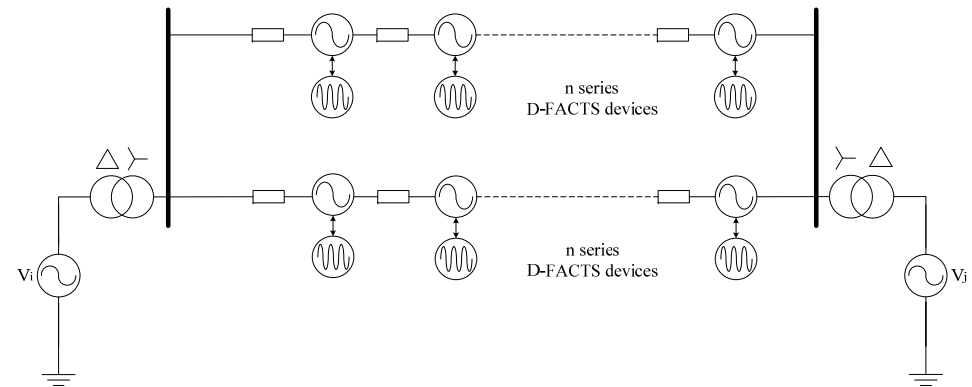

$$P = \sum_{n=1}^{\infty} |V_{sn}| |I_{sn}| \cos \phi_n$$

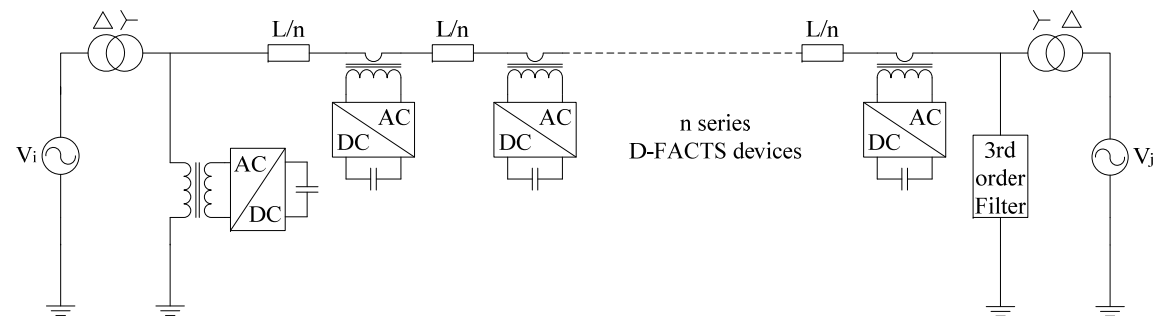

Flexible personality for resilient power limiting grid operation

The stable region of operation of the conventional grid.

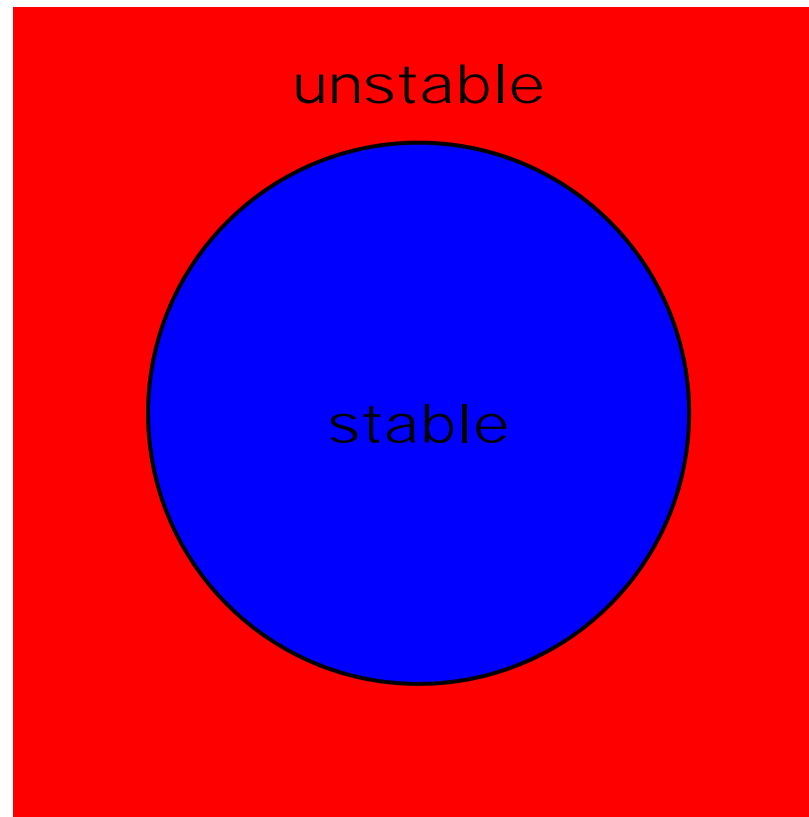

Reduced region of stability due to smaller inertial constant

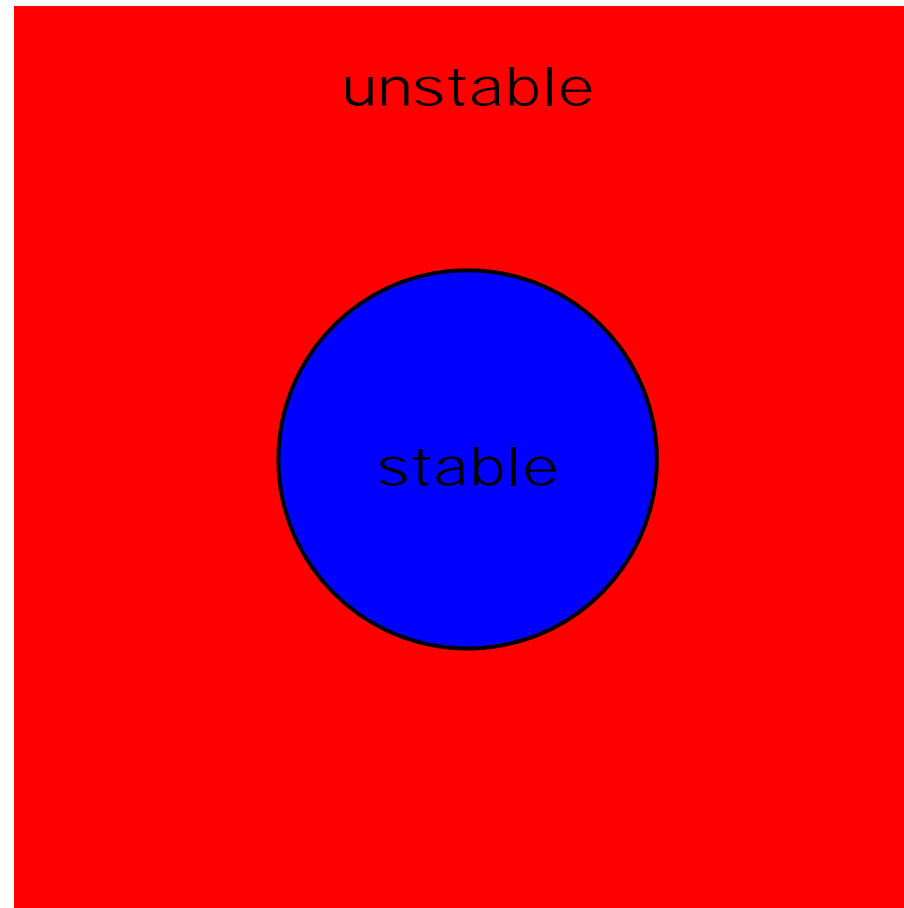

Enhanced region of stability using power electronics

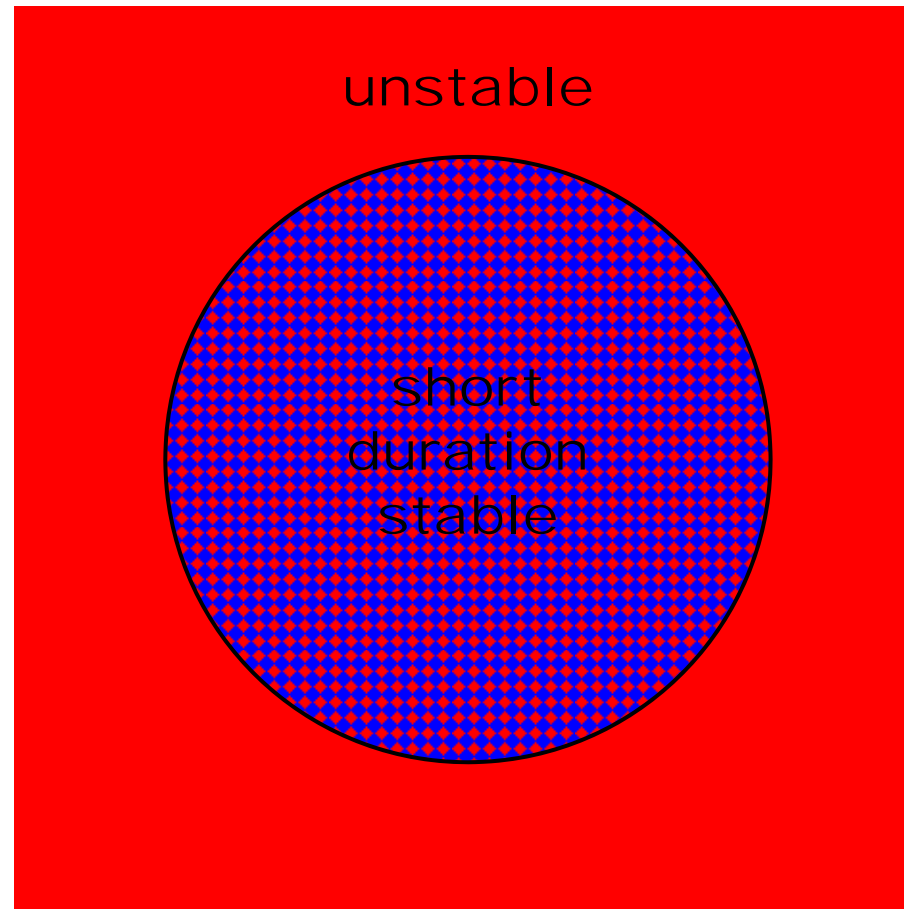

An option is to accept the smaller stable region and limit the power flow in the unstable region

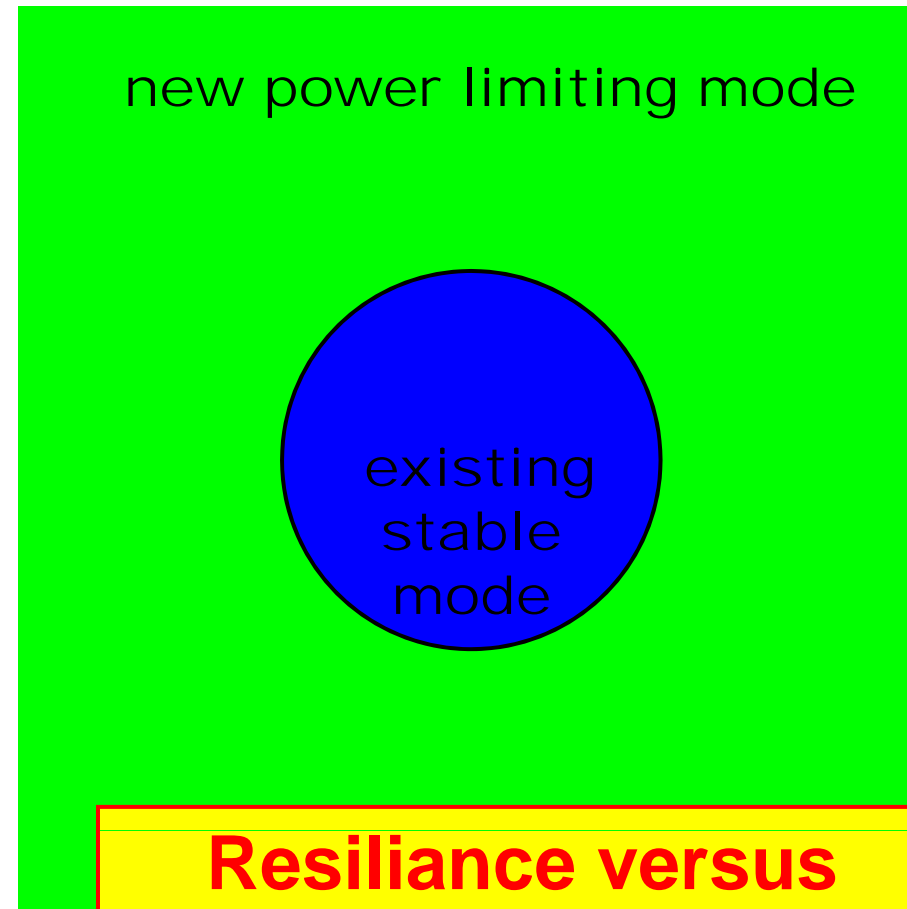

Resilience versus Robustness

Conclusions

- The evolution of power electronics hardware will be accelerated by Wide Bandgap devices. Energy savings and PV systems are the predominant technology driver.
- In Smart Grids power electronics is instrumental to introduce ICT in the system and software/controller development is stimulated
Novel and reliable system concepts are needed.
- Questions?